



**2026 CATALOG**

# STRENGTH EQUIPMENT COLLECTION

[AMERICANSTRENGTH.COM](https://www.americanstrength.com)



Backed by 47 years of relentless pursuit of perfection, American Strength stands at the intersection of precision manufacturing and elite sports performance training.

Every product is built with intention:

**TO INSPIRE, TO ENDURE, AND TO PERFORM.**



**RELENTLESSLY COLLABORATING TO  
CREATE, INSPIRE, EDUCATE & INNOVATE  
FOR HEALTHIER LIVING**





12



61



34



28



24

## CONTENTS

<b>LOWER BODY STRENGTH SERIES</b>	<b>06</b>
POWER SQUAT	<b>08</b>
HACK SQUAT	<b>10</b>
LEG PRESS	<b>12</b>
VERTICAL LEG PRESS	<b>14</b>
BELT SQUAT	<b>16</b>
SEATED CALF RAISE	<b>18</b>
STANDING LEG CURL	<b>20</b>
<b>UPPER BODY STRENGTH SERIES</b>	<b>22</b>
PREACHER CURL BENCH	<b>24</b>
ADJUSTABLE BACK EXTENSION	<b>26</b>
MULTI MIDDLE CHEST	<b>28</b>
T-BAR ROW	<b>30</b>
LAT PULL	<b>32</b>
LOW ROW	<b>34</b>
<b>GLUTE &amp; POSTERIOR CHAIN SERIES</b>	<b>36</b>
HIP THRUSTER	<b>38</b>
STANDING HIP THRUSTER	<b>40</b>
PENDULUM KICK BACK	<b>42</b>
FROG GLUTE PUMP	<b>44</b>
SISSY SQUAT STAND	<b>46</b>
BULGARIAN SQUAT STAND	<b>48</b>
SUMO STAND	<b>50</b>
STANDING ABDUCTOR	<b>52</b>
<b>FUNCTIONAL &amp; CABLE SYSTEMS</b>	<b>54</b>
HI-LOW SINGLE STACK	<b>56</b>
MULTI-JUNGLE 8-STACK	<b>58</b>
DUAL ADJUSTABLE PULLEY	<b>60</b>
CABLE ATTACHMENTS / ACCESSORIES	<b>62</b>
<b>BENCHES &amp; STORAGE SOLUTIONS</b>	<b>64</b>
UTILITY BENCH	<b>66</b>
FLAT BENCH	<b>68</b>
MULTI-ADJUSTABLE BENCH	<b>70</b>
PLATE-LOADED DECLINE OLYMPIC BENCH	<b>72</b>
PLATE-LOADED INCLINE OLYMPIC BENCH	<b>74</b>
PLATE-LOADED FLAT OLYMPIC BENCH	<b>76</b>
PLATE TREE	<b>78</b>
DUMBBELL RACKS	<b>80</b>
ACCESSORY RACK	<b>83</b>
<b>RACKS &amp; RIGS</b>	<b>84</b>
SMITH MACHINE	<b>86</b>

# LOWER BODY STRENGTH SERIES

ENGINEERED FOR POWER AND STABILITY WITH MAXIMUM STRETCH EMPHASIS, THESE PIECES COMBINE BIOMECHANICAL ACCURACY WITH HEAVY-DUTY CONSTRUCTION TO PUSH LEG TRAINING FURTHER.

## PRODUCTS

- POWER SQUAT
- HACK SQUAT
- LEG PRESS
- VERTICAL LEG PRESS
- BELT SQUAT
- SEATED CALF RAISE
- STANDING LEG CURL



AMERICAN STRENGTH

# POWER SQUAT

## PL-PWR-SQT

The American Strength Power Squat combines biomechanical precision, power, and comfort to deliver a world-class lower-body training experience. Engineered for elite performance, it features a precision pivot mechanism for optimal body alignment, and a counterbalanced start position that accommodates users of all levels. The large, adjustable three-position footplate supports multiple squat variations with deep stretch emphasis, while dual-purpose shoulder pads and a patented lumbar pad ensure proper support and spinal integrity throughout each rep. With stainless steel grips, dual safety stops, and a heavy-duty frame, this machine is built for relentless strength sessions and long-term commercial use.

### KEY FEATURES

- Precision pivot mechanism for natural squat motion and body alignment.
- Counterbalanced for a smooth, controlled start weight.
- Dual-purpose shoulder pads and patented lumbar pad for superior comfort.
- Large adjustable three-position footplate for varied stance training and maximum stretch on the target muscles.
- Stainless steel grips and dual-position safety stop for control and confidence.
- Ideal for building quads, glutes, hamstrings, and posterior chain strength.
- Heavy-gauge steel construction with a durable powder-coated finish.

### PRODUCT SPECS:

Length	94.49"/240 CM
Width	55.12"/140 CM
Height	66.93"/170 CM
Weight	732 lb/332 kg



1 Precision pivot mechanism for optimum body alignment (linkage change)



2 Counter balanced for proper start weight



3 Dual-purpose shoulder pads



4 Patented lumbar pad for extra back support



5 Large adjustable 3 position foot plate



6 Stainless steel grip



7 Dual-position safety stops



## AMERICAN STRENGTH HACK SQUAT

### PL-LIN-HCKSQT

The American Strength Hack Squat is designed for serious strength training with smooth, controlled motion and optimal biomechanical alignment. Its rotating back pad allows for both standard and seated squats, while the large, four-position adjustable footplate enables precise targeting of the quads, glutes, and hamstrings with a deep stretch. Featuring a patented lumbar pad for enhanced back support and adjustable safety handles for added confidence, this machine is built for performance and protection. With integrated band pegs for variable resistance and stainless-steel plate holders for ample loading, the Hack Squat delivers professional-grade results for athletes and facilities demanding the best.

### KEY FEATURES

- Ideal for standard and seated hack squats, power and hypertrophy training.
- Rotating back pad supports multiple squat positions with a deep stretch emphasis.
- Large adjustable four-position footplate for targeted lower-body work.
- Patented lumbar pad provides superior spinal support.
- Adjustable and auto-release safety handles for secure operation.
- Band pegs for added or reduced resistance options.
- Four stainless steel plate holders for convenient storage.
- Heavy-gauge steel construction with a durable powder-coated finish.

### PRODUCT SPECS:

Length	94.49"/240 CM
Width	62.99"/160 CM
Height	62.99"/160 CM
Weight	-



4 Stainless steel plate holders



Rotating back pad for standard and seated squats



Rubber band pegs for adding or reducing resistance capability



Auto-release safety handle



Large adjustable 4-position foot plate



Adjustable safety handle



Patented lumbar pad for extra back support



## AMERICAN STRENGTH LEG PRESS

### PL-LEGPRSS-V2

The American Strength Leg Press is built for serious strength development, combining biomechanical precision with unmatched durability and deep stretch on the target muscles. Designed for comfort and control, it features a patented lumbar pad for superior back support and a six-position adjustable footplate to target multiple muscle groups. The adjustable back pad ensures an optimal training angle, while the walk-through design allows for easy entry and exit. With stainless steel multi-grip handles and plate holders for ample loading capacity, this commercial-grade leg press delivers smooth performance, stability, and the power to push limits.

### KEY FEATURES

- Ideal for quad, glute, calf, and hamstring development.
- Large six-position adjustable footplate for varied movement patterns and deep stretch on the target muscles.
- Patented lumbar pad provides enhanced lower back support.
- Adjustable back pad for customized positioning.
- Walk-through design allows easy access and safety.
- Stainless steel multi-grip handle for added control.
- Four stainless steel plate holders for convenient weight storage.
- Heavy-duty steel construction with premium powder-coated finish.

### PRODUCT SPECS:

Length	90.55"/230 CM
Width	60.24"/153 CM
Height	55.12"/140 CM
Weight	644 LB/292 KG



1 Large adjustable 6 position foot plates



2 Patented lumbar pad for extra back support



3 Adjustable back pad for user preference



4 Stainless multi-grip handle



5 Walk through feature easy entry and exit



6 4 Stainless steel plate holders



## AMERICAN STRENGTH VERTICAL LEG PRESS

### PL-VERT-LEGRSS

The American Strength Vertical Leg Press delivers uncompromising power and precision in a compact, space-efficient design. Engineered for maximum lower-body development, it provides a true vertical press path that isolates the quads, glutes, and hamstrings while minimizing spinal load. A large three-position adjustable footplate allows users to vary stance and muscle engagement, and the adjustable head pad offers incline, flat, or decline positioning for total comfort. With band pegs for progressive resistance, stainless steel plate holders, and an auto-release safety arm, this machine combines safety, versatility, and commercial-grade durability in one sleek package.

### KEY FEATURES

- Vertical press path for optimal quad, glute, and hamstring activation.
- Large adjustable footplate with three training positions.
- Adjustable head pad with incline, flat, and decline settings.
- Rubber band pegs for variable resistance training.
- Stainless multi-grip handle for control and stability.
- Auto-release safety arm for smooth operation.
- Four stainless steel plate holders for easy weight access.
- Heavy-duty steel frame with durable powder-coated finish.

### PRODUCT SPECS:

Length	70.87"/180 CM
Width	80.71"/205 CM
Height	82.68"/210 CM
Weight	573 LB/260 KG



4 Stainless steel plate holders



Auto-release safety arm



Rubber band pegs for added resistance capability



Stainless multi-grip handle



Adjustable head pad with 3 different positions, incline, flat & decline



Large adjustable 3 position foot plate

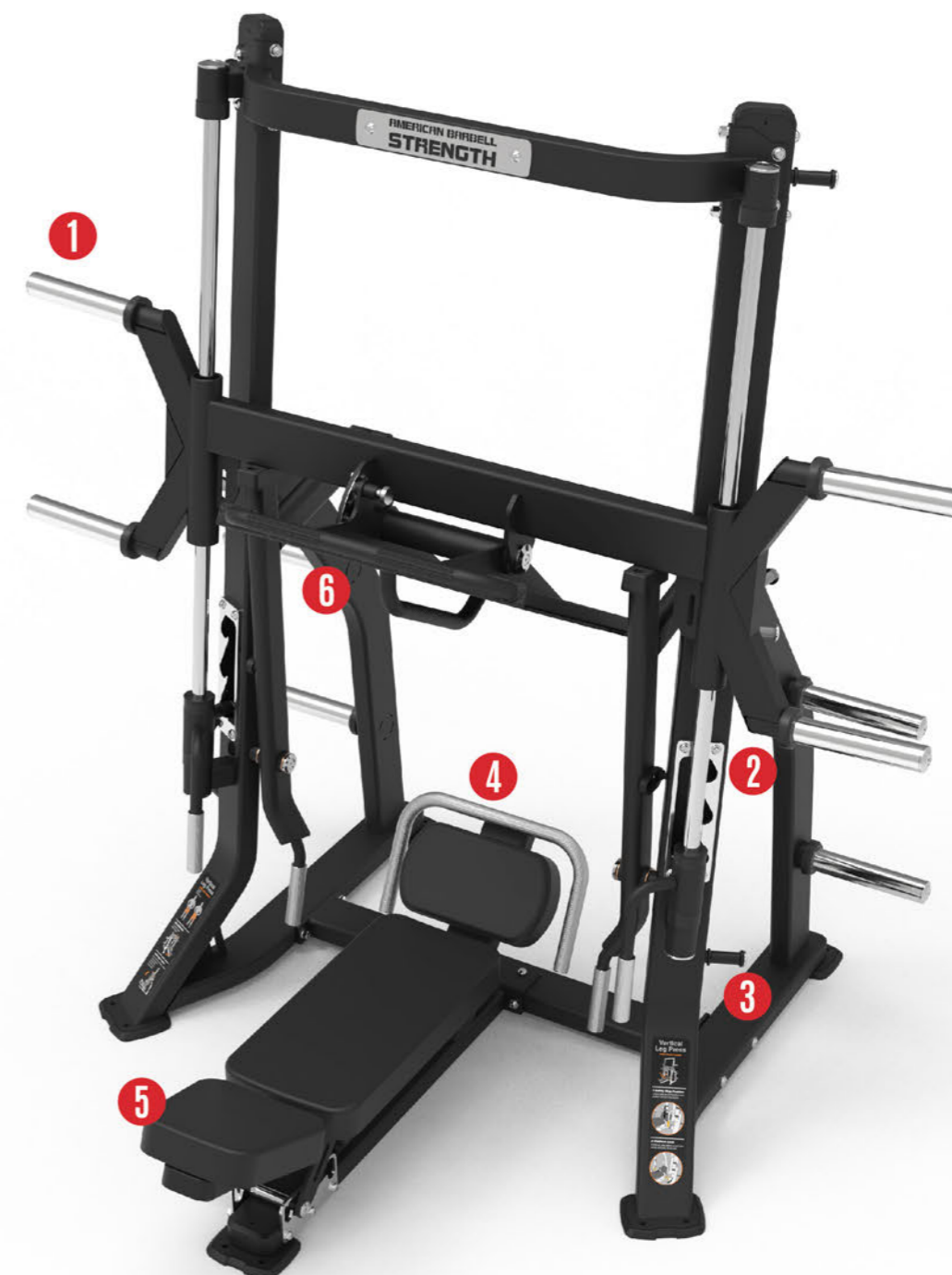

## AMERICAN STRENGTH BELT SQUAT

### PL-BLTSQT

The American Strength Belt Squat is engineered for unmatched lower-body training without spinal loading. Designed to build strength and power through the quads, glutes, and hamstrings, it delivers the benefits of squatting with reduced stress on the back and shoulders. The adjustable footplate offers flat, incline, and decline options for varied muscle activation and deep stretch, while the fully knurled handlebar and auto-release mechanism provide control and safety during every rep. With band pegs for variable resistance and a heavy-gauge steel frame, this Belt Squat stands up to the most demanding commercial environments.

### KEY FEATURES

- Ideal for belt squats, lunges, and lower-body accessory movements.
- Reduces spinal loading while maximizing leg and glute engagement.
- Adjustable footplate with flat, incline, and decline positions, while allowing for a deep stretch in the target muscles.
- Auto-release handle for smooth operation and added safety.
- Fully knurled handlebar for secure grip.
- Integrated band pegs for progressive resistance.
- Anti-slip footplate for enhanced stability.
- Heavy-duty construction for commercial use.

### PRODUCT SPECS:

Length	75.75" / 192.4 CM
Width	43.07" / 109.4 CM
Height	52.4" / 133.1 CM
Weight	327 LB / 148 KG



Auto-release handle



Fully knurled handle bar for positive grip



Adjustable footplate with 3 different angles: flat, incline, and decline.



Anti-slip foot plate for stability



Rubber band pegs for added resistance capability



AMERICAN STRENGTH

# SEATED CALF RAISE

## PL-ST-CLF

The American Strength Seated Calf Raise is built for peak performance and precision isolation of the lower legs. Designed to deliver a smooth and natural motion, it effectively targets the soleus and gastrocnemius muscles for improved strength, stability, and definition. The heavy-duty frame and pivoting movement arm ensure consistent resistance and a controlled range of motion, while the adjustable thigh pad accommodates users of all sizes. With diamond-plated foot platforms for stability and stainless-steel handles for comfort and durability, this commercial-grade piece is made to stand up to years of high-volume use.

### KEY FEATURES

- Targets the soleus and gastrocnemius for lower leg development.
- Adjustable thigh pad for user comfort and fit.
- Smooth pivoting resistance for controlled motion.
- Diamond-plated foot platform for secure positioning.
- Stainless steel handles for comfort and longevity.
- Compact, heavy-duty design ideal for commercial gyms and training facilities.

### PRODUCT SPECS:

Length	55.59"/141.2 CM
Width	28.74"/73 CM
Height	36.65"/93.1 CM
Weight	126 LB/57 KG



AMERICAN STRENGTH

# STANDING LEG CURL

## PL-ST-LG-CRL

The American Strength Standing Leg Curl is built to hammer hamstrings with clean mechanics, hard contractions, and zero wasted reps. Designed for controlled knee flexion and consistent tension through the full range, it delivers a smooth, powerful curl pattern that supports strength development, hypertrophy, and athletic posterior chain training.

Adjustable positioning and secure contact points keep athletes locked in, while the heavy-duty frame stays planted under real loading and high-volume use. When it's time to build stronger hamstrings and protect the knees, this is the tool.

### KEY FEATURES

- Targeted hamstring isolation for strength, hypertrophy, and posterior chain development.
- Smooth, controlled resistance path for consistent tension and clean reps.
- Adjustable setup to fit a wide range of athletes and dialing in positioning.
- Secure pads + contact points for locked-in stability and powerful contractions.
- Heavy-duty steel construction engineered for commercial use and daily abuse.
- Built for performance programming: strength blocks, accessory work, and rehab-style control.

### PRODUCT SPECS:

Length	62"/1570 CM
Width	44"/1115 CM
Height	52"/1330 CM
Weight	245 LB/111.1 KG



# UPPER BODY STRENGTH SERIES

**BUILT FOR BALANCED POWER, DEEP STRETCH BIOMECHANICAL PRECISION, OUR UPPER-BODY LINE TRAINS EVERY ANGLE WITH NATURAL MOTION AND UNRIVALED DURABILITY.**

## PRODUCTS

- PREACHER CURL BENCH
- ADJUSTABLE BACK EXTENSION
- MULTI MIDDLE CHEST
- T-BAR ROW
- LAT PULL
- LOW ROW



UPPER BODY STRENGTH SERIES



AMERICAN STRENGTH

# PREACHER CURL BENCH

## PL-PRCHR-CRL

The American Strength Preacher Curl Bench is built for ruthless arm development and clean, controlled reps. Designed to lock the upper arm in place and eliminate momentum, it forces the biceps to do the work, no swinging, no shortcuts. The angled pad supports strict positioning for hard contractions and full-range training, making it ideal for hypertrophy blocks, accessory programming, and strength-focused arm work. With a heavy-duty steel frame and stable base, this bench stays planted under real loading and high-volume sessions. Pure isolation. Pure output.

### KEY FEATURES

- Angled preacher pad for strict arm positioning and maximum biceps isolation.
- Eliminates momentum to keep tension where it belongs, on the muscle.
- Stable, heavy-duty frame built for aggressive loading and daily use.
- Ergonomic setup for consistent rep mechanics and clean execution.
- Ideal for hypertrophy + accessory work in strength programs and bodybuilding splits.
- Durable commercial-grade finish designed to hold up in high-traffic gyms.

### PRODUCT SPECS:

Length	42"/1062 CM
Width	36.5"/925 CM
Height	35"/880 CM
Weight	117 LB/53 KG



AMERICAN STRENGTH

# ADJUSTABLE BACK EXTENSION

## BNCH-BCKEXT-V2

The American Strength Adjustable Back Extension is built to strengthen the posterior chain the right way, controlled, loaded, and repeatable. Designed for hip-hinge mechanics and targeted low-back, glute, and hamstring development, it features an adjustable setup to lock athletes into the correct position and hit full-range reps without compensation. The stable base keeps the unit planted during high-volume training, while integrated foot support and durable padding deliver consistent bracing rep after rep. Whether you're building spinal resilience, reinforcing hinge patterns, or finishing a strength session with accessory work, this piece is pure output for the backside.

### KEY FEATURES

- Adjustable positioning to dial in proper hip-hinge mechanics and athlete fit.
- Targets posterior chain: lower back, glutes, and hamstrings with controlled loading.
- Stable, heavy-duty frame built for aggressive training and daily commercial use.
- Secure foot platform + ankle rollers for strong bracing and consistent execution.
- High-density padding for support without instability during high-rep volume.
- Ideal for strength, rehab-style control, and accessory programming to build durability and power.
- Commercial-grade durability engineered for high-traffic training floors.

### PRODUCT SPECS:

Length	48.50"/1230 CM
Width	34"/870 CM
Height	33"/840 CM
Weight	110 LB/50 KG



AMERICAN STRENGTH

# MULTI MIDDLE CHEST

## PL-MM-CHST-FLY

The American Strength Multi Middle Chest is engineered for strength, stability, and precise pressing mechanics. Designed to deliver the perfect mid-range chest press, it offers an ideal movement path that enhances deep stretch muscle engagement while minimizing shoulder strain. The adjustable seat and back pad ensure optimal alignment for users of all sizes, while stainless steel grips and a wide pressing arc create a smooth, natural motion. Built for durability and consistent performance, the Multi Middle Chest is an essential addition to any commercial facility or performance training center focused on balanced upper-body development.

### KEY FEATURES

- Ideal for lower, mid-range, and upper chest press and pectoral development.
- Biomechanically aligned pressing arms for smooth, natural motion and deep stretch emphasis on the target muscles.
- Adjustable seat and back pad for user comfort and alignment.
- Stainless steel grips for control and longevity.
- Durable construction with high-grade upholstery and powder-coated frame.
- Compact design optimized for commercial and performance training spaces.

### PRODUCT SPECS:

Length	76.46" / 194.2 CM
Width	61.57" / 156.4 CM
Height	40.59" / 103.1 CM
Weight	243 LB / 110 KG



AMERICAN STRENGTH

# T-BAR ROW

## PL-T-BAR-RW

The American Strength T-Bar Row is built to deliver powerful, controlled back training with unmatched stability, and ergonomic precision and a deep stretch emphasis on target muscle groups. Designed to maximize upper and mid-back engagement, it features a wide diamond-plated foot platform for secure footing and a smooth pivot point for consistent resistance throughout the range of motion. The angled chest pad supports proper body positioning and minimizes lower-back strain, allowing for intense and effective training sessions. Constructed from heavy-gauge steel with stainless steel grip handles, this T-Bar Row is made for serious lifters and commercial environments demanding durability and performance.

### KEY FEATURES

- Ideal for building strength and size in the lats, traps, and rhomboids, while allowing for a deep stretch in the target muscles.
- Angled chest pad for comfort and spinal alignment.
- Diamond-plated platform for stable foot positioning.
- Precision pivot for smooth, consistent resistance.
- Stainless steel multi-grip handles for varied hand positions.
- Heavy-duty construction with a durable powder-coated finish.
- Compact footprint ideal for commercial gyms and performance facilities.

### PRODUCT SPECS:

Length	75.51"/191.8 CM
Width	35.63"/90.5 CM
Height	23.58"/59.9 CM
Weight	225 LB/102 KG

UPPER BODY  
STRENGTH SERIES

AMERICAN STRENGTH

# LAT PULL-DOWN

## PL-PULLDOWN-B

The Flight Series Plate Loaded Lat Pull-Down by American Strength is a robust and biomechanically sound machine designed for compound training – primarily targeting the lats while also engaging the biceps, forearms, and middle back. With multiple grip positions, it allows lifters to alternate between traditional overhand (pronated) pulls and underhand (supinated) pulls for increased bicep emphasis.

Single-arm mechanics enable maximum muscle isolation and activation. The easy and tactile seat adjustment ensures users can quickly and safely find their ideal position. Finished in classic Matte Black, it delivers long-lasting durability and timeless aesthetics.

### KEY FEATURES

- Multiple grip positions for varied lat and bicep emphasis, including pronated and supinated pulls.
- Single-arm mechanics for enhanced muscle isolation and back activation.
- Easy, tactile seat adjustment for quick and safe positioning.
- Classic Matte Black finish for durability and timeless appeal.
- 11 & 8-gauge steel construction with stainless steel weight pegs for long-term performance.
- Supports up to 450 lb (204 kg) weight load with 600+ lb (275+ kg) storage capacity across 4 pegs.
- Grip diameter of 1.25" (32 mm).

### PRODUCT SPECS:

Length	66"/168 CM
Width	51"/130 CM
Height	76.5"/194 CM
Weight	326 LB/148 KG



## AMERICAN STRENGTH

# LOW ROW

### PL-LOWROW-B

The **Flight Series Plate Loaded Low Row** by American Strength is a robust and biomechanically optimized machine designed as an effective alternative to traditional dumbbell and seated row variations. Featuring an ideal pulling angle and multiple grip options, it allows for varied degrees of rowing emphasis. Single-arm mechanics maximize muscle isolation and activation, while the easy and tactile seat adjustment ensures quick and secure setup. Finished in classic Matte Black, it offers long-lasting durability and a timeless aesthetic.

#### KEY FEATURES

- Multiple grip positions for varied rowing angles and muscle emphasis.
- Single-arm mechanics for enhanced muscle isolation and full back activation.
- Easy, tactile seat adjustment for fast and safe positioning.
- Classic Matte Black finish for durability and a clean, modern design.
- 11 & 8-gauge steel construction with stainless steel storage pegs.
- Supports up to 992 lb (450 kg) maximum load with 600+ lb (275+ kg) storage capacity across 4 pegs.
- Grip diameter of 1.25" (32 mm).

#### PRODUCT SPECS:

Length	61"/155 CM
Width	50.5"/128 CM
Height	67"/170 CM
Weight	345 LB/156 KG



# GLUTE & POSTERIOR CHAIN SERIES

FROM GLUTE ACTIVATION TO FULL POSTERIOR-CHAIN ENGAGEMENT, THIS SERIES DELIVERS STRENGTH, BALANCE, DEEP STRETCH, AND PERFORMANCE THROUGH PRECISION MOVEMENT.

## PRODUCTS

- HIP THRUSTER
- STANDING HIP THRUSTER
- PENDULUM KICK BACK
- FROG GLUTE PUMP
- SISSY SQUAT STAND
- BULGARIAN SQUAT STAND
- SUMO STAND
- STANDING ABDUCTOR



GLUTE & POSTERIOR CHAIN SERIES

AMERICAN STRENGTH

# HIP THRUSTER

## PL-HIPTHR-V2

The American Strength Hip Thruster is engineered for explosive glute training and total lower-body development. Built for strength, safety, and versatility, it features a stable raised foot platform, oversized support pad, and an adjustable head pad for proper positioning and comfort. Rubber band pegs allow variable resistance for progressive loading, while the auto-release safety arm ensures smooth transitions during training. Designed for commercial performance and durability, this Hip Thruster is the ultimate tool for glute bridges, hip thrusts, and advanced posterior chain work.

### KEY FEATURES

- Ideal for hip thrusts, glute bridges, and posterior chain strengthening, while allowing for a deep stretch in the target muscles.
- Oversized support pad with adjustable headrest for comfort and alignment.
- Raised diamond plate foot platform for secure positioning.
- Integrated band pegs for accommodating or adding resistance.
- Auto-release safety arm for efficient setup and movement.
- Heavy-duty steel construction built for commercial use.
- Durable powder-coated finish resists wear and corrosion.

### PRODUCT SPECS:

Length	62.91"/159.8 CM
Width	65.91"/167.4 CM
Height	39.61"/100.6 CM
Weight	300 LB/136 KG



Oversized Support Pad



Tilted head pad for proper support



Rubber band pegs for adding or reducing resistance capability



Auto-release safety arm



Stable, raised foot platform for secure positioning



AMERICAN STRENGTH

# STANDING HIP THRUSTER

## PL-ST-HP-THRST

The American Strength Standing Hip Thruster brings power and precision to glute and posterior chain training. Designed for controlled, standing hip thrust movements, it targets the glutes, hamstrings, and hips through a natural, upright range of motion, and with a deep stretch in the target muscles. The fully knurled handlebar ensures a secure grip, while band pegs allow for progressive resistance. Its anti-slip footplate and heavy-gauge steel construction provide unmatched stability, and built-in transport wheels make movement effortless. This compact, commercial-grade machine delivers a powerful new way to train strength, stability, and symmetry.

### KEY FEATURES

- Ideal for standing hip thrusts, glute activation, and lower body strengthening, while allowing for a deep stretch in the target muscles.
- Fully knurled handlebar for secure grip and control.
- Band pegs for adding or reducing resistance.
- Anti-slip diamond footplate for safety and stability.
- Heavy-duty steel frame built for commercial environments.
- Wheels on frame for easy portability.
- Durable powder-coated finish resists impact and wear.

### PRODUCT SPECS:

Length	47.13"/119.7 CM
Width	47.24"/120 CM
Height	54.37"/138.1 CM
Weight	205 LB/93 KG



Fully knurled handle bar



Wheels on frame for easy machine movement



Anti-slip foot plate for stability



Rubber band pegs for added resistance capability



AMERICAN STRENGTH

# PENDULUM KICK BACK

The American Strength Pendulum Kick Back is engineered for precision glute and hamstring engagement with unmatched control and deep stretch on the target muscles. Its pendulum-style movement delivers smooth, natural resistance throughout the range of motion, maximizing muscle activation while minimizing joint strain. The adjustable knee pad and range of motion settings accommodate users of all sizes, while band pegs offer variable resistance for progressive training. With a fully knurled handlebar for grip and a counterbalanced design for proper starting weight, this machine combines performance, comfort, and durability for serious strength development.

## KEY FEATURES

- Ideal for glute kickbacks, hip extensions, and hamstring activation.
- Pendulum movement provides smooth, controlled resistance, while allowing for a deep stretch in the target muscles.
- Adjustable knee pad and motion range for personalized fit and comfort.
- Counterbalance ensures proper start weight and natural feel.
- Integrated band pegs for resistance customization.
- Fully knurled handlebar for stability and control.
- Heavy-duty construction built for commercial environments.

## PRODUCT SPECS:

Length	57.99"/147.3 CM
Width	58.31"/148.1 CM
Height	58.15"/147.7 CM
Weight	342 LB/155 KG



1 Fully knurled handle bar for positive grip



2 Counter-balance for proper start weight



3 Adjustable range of motion for a comfortable starting position



4 Rubber band pegs for added resistance capability



5 Adjustable knee pad to accommodate different user heights



AMERICAN STRENGTH

# FROG GLUTE PUMP

**PL-FRG-PRSS**

The American Strength Frog Glute Pump is engineered to deliver deep glute activation and full-range posterior chain engagement. Designed with an angled frame for optimal biomechanics, it promotes natural movement, maximum stretch and consistent tension throughout every rep. Adjustable range of motion and foot bar settings allow users to customize positioning for comfort and performance, while band pegs enable variable resistance for progressive overload. Built for commercial-grade use, the Frog Pump combines ergonomic precision with the rugged durability American Strength is known for.

## KEY FEATURES

- Ideal for glute pumps, hip extensions, and posterior chain activation.
- Angled frame design enhances range of motion, deep stretch and muscle engagement.
- Adjustable foot bar accommodates different user heights.
- Range of motion adjustment for safe entry and exit.
- Rubber band pegs for variable resistance training.
- Fully knurled handlebar for control and stability.
- Heavy-duty steel construction with a durable powder-coated finish.

## PRODUCT SPECS:

Length	75.71"/192.3 CM
Width	43.7"/111 CM
Height	70.24"/178.4 CM
Weight	335 LB/152 KG



1 Fully knurled handle bar for positive grip



2 Angled frame design for better range of motion



3 Footbar adjusts to fit user height for effective workout



4 Rubber band pegs for added resistance capability



5 Range of motion adjustment for easy entry and exit



GLUTE & POSTERIOR  
CHAIN SERIES

AMERICAN STRENGTH

# SISSY SQUAT STAND

## PL-SSY-SQT

The American Strength Sissy Squat Stand is engineered for serious lower-body training in a compact footprint. Designed to build quad strength, core stability, and balance, it's ideal for sissy squats, bodyweight extensions, and controlled eccentric work—while allowing for maximum stretch in the quads. The adjustable leg pads and contoured calf support provide a secure, comfortable fit for all athletes, while the non-slip diamond plate foot platform ensures stability through every rep. Built from heavy-duty steel and finished with a durable powder coat, this stand delivers commercial-grade performance in any training environment.

### KEY FEATURES

- Perfect for sissy squats, bodyweight extensions, and core stabilization work.
- An excellent alternative to conventional quad training, while allowing for deep stretch in the target muscle.
- Adjustable rollers and calf support for optimal positioning.
- Diamond plate foot platform for maximum grip and safety.
- Heavy-gauge steel frame for lasting durability.
- Compact design ideal for any gym or performance space.
- Integrated transport wheels for easy movement.

### PRODUCT SPECS:

Length	39"/99 CM
Width	29.8"/75.6 CM
Height	19"/48.3 CM
Weight	75 LB/34 KG



AMERICAN STRENGTH

# BULGARIAN SQUAT STAND

## PL-BLGRN-PRO

The American Strength Bulgarian Squat Stand is built for power, balance, and precision. Designed to elevate single-leg training, it supports exercises like Bulgarian split squats, rear-foot elevated lunges, and step-ups, while offering a deep stretch in target muscles. The dense foam roller pad provides superior comfort and stability, while the heavy-duty steel frame ensures maximum durability under load. Compact and efficient, it's an essential tool for building lower-body strength and correcting muscle imbalances in any commercial or home training space.

### KEY FEATURES

- Ideal for Bulgarian split squats, single-leg squats, lunges, and step-ups, while offering a deep stretch in the target muscles.
- High-density roller pad for secure and comfortable support.
- Heavy-gauge steel construction for long-term durability.
- Compact design for space-efficient setups.
- Non-slip base for added stability during training.
- Durable powder-coated finish resists corrosion and wear.

### PRODUCT SPECS:

Length	33.43"/84.9 CM
Width	16.54"/42 CM
Height	21.3"/54.1 CM
Weight	53 LB/24 KG



AMERICAN STRENGTH

# SUMO STAND

## PL-SMO-BNCH

The American Strength Sumo Stand is engineered to enhance stance stability, hip strength, and posterior chain activation. Its elevated, angled foot platforms promote optimal positioning for sumo squats, deadlifts, glute work, and mobility training, while allowing for maximum stretch. Built from heavy-duty steel with a diamond plate surface for superior traction, this stand supports powerful lower-body performance and proper form. Compact, durable, and designed for serious lifters, the Sumo Stand is a must-have addition to any commercial or performance gym.

### KEY FEATURES

- Ideal for sumo squats, deadlifts, glute activation, and stance training, while allowing for maximum stretch in the target muscles.
- Angled platforms promote proper alignment and depth control.
- Diamond plate surface provides grip and stability.
- Heavy-gauge steel frame built for commercial durability.
- Compact design fits easily into any training space.
- Durable powder-coated finish resists wear and corrosion.

### PRODUCT SPECS:

Length	38.6"/98.1 CM
Width	28.1"/71.5 CM
Height	12.3"/31.2 CM
Weight	75 LB/34 KG



## AMERICAN STRENGTH STANDING ABDUCTOR

### PL-ST-ABDCTR

The American Strength Standing Abductor is built to strengthen and sculpt the glutes, hips, and outer thighs with precision and power. Its upright design promotes balance, core engagement, and proper alignment, while the smooth motion path ensures consistent muscle activation through every rep. The fully knurled handlebar provides a secure grip, and integrated band pegs allow users to adjust resistance for progressive overload. With anti-slip footplates and heavy-gauge steel construction, this machine delivers premium performance and durability in any training environment.

### KEY FEATURES

- Targets glutes, hips, and outer thighs for strength and stability.
- Upright design enhances posture and core engagement.
- Rubber band pegs for variable resistance training.
- Fully knurled handlebar for secure support.
- Anti-slip footplates for safety and stability.
- Heavy-duty steel frame built for commercial environments.
- Durable powder-coated finish resists wear and corrosion.

### PRODUCT SPECS:

Length	61.81"/157 CM
Width	32.99"/83.8 CM
Height	56.77"/144.2 CM
Weight	262 LB/119 KG



1 Fully knurled handle bar for positive grip



2 Rubber band pegs for added resistance capability



3 Anti-slip foot plates for stability



# FUNCTIONAL & CABLE SYSTEMS

OUR FUNCTIONAL TRAINERS COMBINE PRECISION MECHANICS WITH LIMITLESS VERSATILITY, DELIVERING SMOOTH, CONTROLLED RESISTANCE FOR EVERY MOVEMENT PATTERN.

## PRODUCTS

- HI-LOW SINGLE STACK
- MULTI-JUNGLE 8-STACK
- DUAL ADJUSTABLE PULLEY
- CABLE ATTACHMENTS / ACCESSORIES

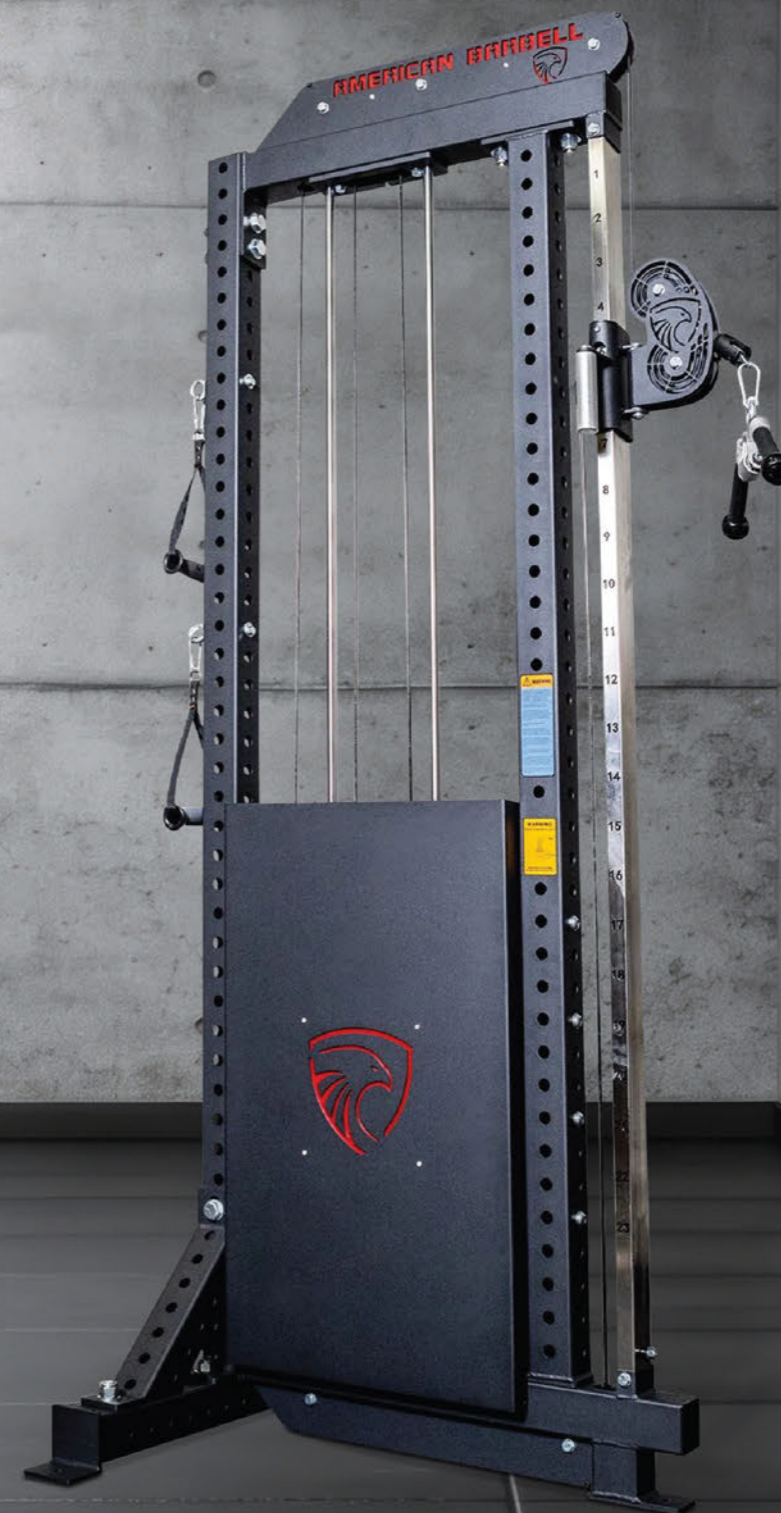

AMERICAN STRENGTH

# HI-LOW SINGLE STACK

## ECORG-HLO94

Our new **Hi-Low Single Stack** was meticulously engineered to enhance your resistance training. It features a solid 3x3" steel construction along with a 200LB weight stack. This rack was designed not only to be a durable solution, but one with classic aesthetics and functionality.

Height adjustments are made easily, with a knurled handle. Additionally, we used stainless steel on the height adjustment column to eliminate peeling and chipping, commonly seen with even light use on other finishes.

### KEY FEATURES

- Knurled adjustment handle.
- Stainless Steel height adjustment column (will not peel or chip away and far superior to other finishes here).
- 3x3" 11 gauge steel, 3/4" hardware.
- American Barbell "Shield" machined pulley cages.
- Can be attached to compatible Rig or Rack units.
- Weight listed in LB & KG.
- **Footprint:** 94" X 38" X 34".

### PRODUCT SPECS:

Length	61.81"/157 CM
Width	32.99"/83.8 CM
Height	56.77"/144.2 CM
Weight	262 LB/119 KG



AMERICAN STRENGTH

# MULTI-JUNGLE 8-STACK

## PL-MJ-8STK

The American Strength Multi-Jungle 8-Stack is a high-output cable system built for full-facility performance and nonstop traffic. Configurable as a 4-station or 8-station system, and expandable as your facility grows, it delivers the versatility to run strength circuits, athletic programming, group training, and accessory work, all at once.

Precision pulleys and smooth cable travel keep movement clean under load, while the multi-grip pull-up options and integrated attachments expand your exercise library without adding clutter. This is the centerpiece for serious training floors: maximum capacity, maximum versatility, zero wasted space.

### KEY FEATURES

- Configurable system: available in 4-station or 8-station configurations and expandable as facility needs grow.
- 8 independent weight stacks to support multiple users and high-volume sessions.
- Multi-station training for full-body strength, conditioning, and accessory work.
- Smooth cable travel + precision pulleys for consistent resistance and clean reps.
- Integrated multi-grip pull-up bars for upper-body strength and grip development.
- Built for circuits + group training to keep athletes moving with minimal downtime.
- Durable commercial-grade frame engineered for nonstop use in high-traffic facilities.
- Versatile attachment options for presses, pulls, rotations, cable crossover, and rehab work.
- Space-efficient layout that maximizes training output per square foot.

### PRODUCT SPECS:

Length	61.81"/157 CM
Width	32.99"/83.8 CM
Height	56.77"/144.2 CM
Weight	262 LB/119 KG

### 8 WEIGHT STACKS:

(2) Triceps Extension	170 LBS / 77.1 KG WEIGHT STACK
(2) Hi-Lo Pulley	200 LBS / 90.7 KG WEIGHT STACK
(2) Lat Pulldown	300 LBS / 136.1 KG WEIGHT STACK
(2) Low Row	300 LBS / 136.1 KG WEIGHT STACK



AMERICAN STRENGTH

# DUAL ADJUSTABLE PULLEY

## ECORG-DUALADJPLY-V2-B

The American Strength Dual Adjustable Pulley is built for versatile, full-body training with smooth movement, consistent resistance, and commercial-grade durability. Designed to support a wide range of strength and accessory work, it allows athletes to dial in precise pulley positions for controlled pulling and pressing patterns, isolation work, and functional training progressions. With dual independent pulleys and quick adjustments, it adapts to different body sizes, training goals, and movement setups, making it a true cornerstone piece for busy floors. Stable under load and easy to use, it delivers clean reps and reliable performance session after session.

### KEY FEATURES

- Dual independent pulleys for unilateral and bilateral training.
- Quick-adjust pulley positioning to match a wide range of exercises and user setups.
- Smooth cable travel for consistent resistance and controlled movement.
- Versatile exercise options for upper body, lower body, and core training.
- Designed for efficient training flow, ideal for high-traffic facilities.
- Heavy-duty frame construction built for long-term commercial use.
- Multiple handle positions and attachments compatibility to expand training variety.

### PRODUCT SPECS:

Depth	734"/1864 CM
Width	409"/1039 CM
Height	940"/2388 CM
Weight	995"/451.3 CM
Stacks	300"/136.1 CM

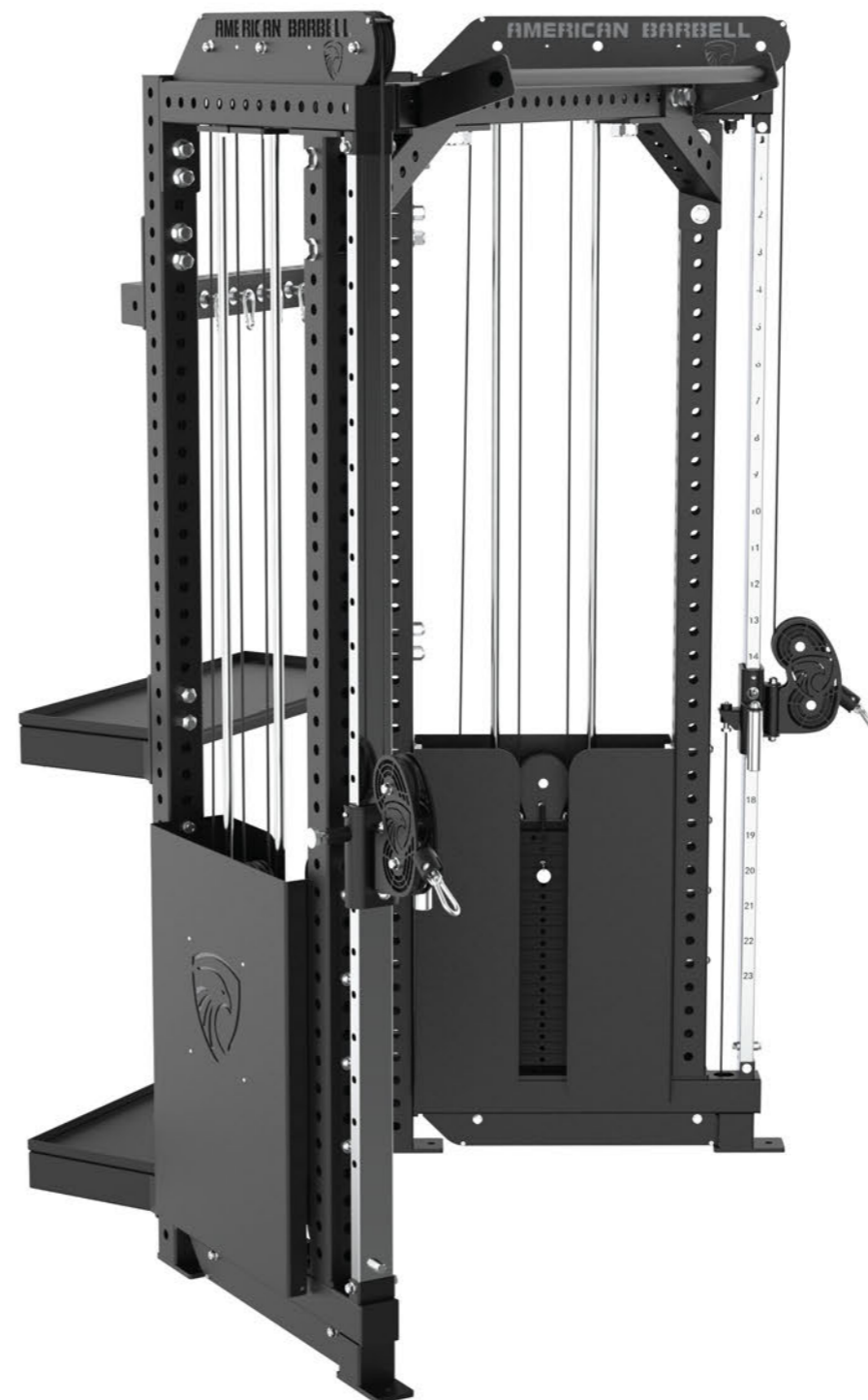

AMERICAN STRENGTH

# CABLE ATTACHMENTS / ACCESSORIES

## ST-ACC-B

The American Strength 16 Piece Accessory Rack is engineered for maximum efficiency in any training environment. Built from solid heavy-gauge steel, it serves as a durable central hub for organizing essential gym accessories. With two rubber-coated trays for miscellaneous items and multiple posts that accommodate a wide range of attachments—from cable accessories to bar collars and straps—this rack keeps equipment visible, accessible, and ready for use.

Eight dedicated bar holders and eight accessory hooks, each fitted with plastic protection, help preserve equipment quality and keep your training area clean and orderly. The rack's stable base can also be bolted down for enhanced security in high-traffic facilities.

### KEY FEATURES

- Heavy-gauge steel construction for long-term durability and commercial-grade performance.
- Multiple storage posts supporting cable attachments, bar collars, straps, and specialty handles.
- Includes 8 bar holders, 8 accessory hooks, and 2 rubber-coated trays for small items.
- Plastic-protected hooks to reduce wear and extend the life of accessories.
- Sturdy feet with bolt-down capability for added stability.
- Clean, space-efficient design suitable for commercial or home gym setups.

### PRODUCT SPECS:

Depth	24"/61 CM
Width	24"/61 CM
Height	36"/91.4 CM
Weight	-



# BENCHES & STORAGE SOLUTIONS

CLEAN DESIGN MEETS HEAVY-DUTY PERFORMANCE, THE FOUNDATION PIECES THAT KEEP YOUR FACILITY EFFICIENT, ORGANIZED, AND ATHLETE READY.

## PRODUCTS

- UTILITY BENCH
- FLAT BENCH
- MULTI-ADJUSTABLE BENCH
- PLATE-LOADED DECLINE OLYMPIC BENCH
- PLATE-LOADED INCLINE OLYMPIC BENCH
- PLATE-LOADED FLAT OLYMPIC BENCH
- PLATE TREE
- DUMBBELL RACKS
- ACCESSORY RACK



AMERICAN STRENGTH

# UTILITY BENCH

## BNCH-UTLY-V2

The American Strength Utility Bench is a no-excuses training staple built for heavy presses, aggressive accessory work, and nonstop daily abuse. Engineered for stability under load, it delivers a rigid, locked-in platform for dumbbell training, barbell support work, and unilateral movements, without shifting, flexing, or wobble. From bench press variations and rows to core work, this bench is designed to keep athletes in position and training at full output rep after rep. Built for performance. Built to take hits.

### KEY FEATURES

- Rigid steel frame for zero-flex performance under heavy loading.
- Stable base + non-slip feet for secure contact on any training floor.
- Training-optimized pad geometry for consistent setup and positioning.
- High-density padding for support without sink, ideal for pressing volume.
- Compact footprint that fits seamlessly in racks, dumbbell zones, and functional spaces.
- Built for versatility: presses, rows, split stances, and accessory work.
- Commercial-grade durability made for high-traffic facilities and relentless use.

### PRODUCT SPECS:

Length	31"/778 CM
Width	30.50"/775 CM
Height	36"/904 CM
Weight	60 LB/27 KC



AMERICAN STRENGTH

# FLAT BENCH

## BNCH-FLT-UT-V2

The American Strength Flat Bench is the definition of a workhorse, built for heavy pressing, aggressive dumbbell training, and high-volume accessory work without compromise. Engineered with a rigid steel frame and a stable, non-slip base, it delivers a locked-in platform that stays planted under real loading.

The wide, supportive pad keeps positioning consistent for clean reps and repeat output, while the compact footprint makes it easy to move between racks, dumbbell zones, and functional spaces. No gimmicks. No flex. Just a flat bench built to take a beating.

### KEY FEATURES

- Rigid steel construction for zero-flex stability under heavy loads.
- Stable base + non-slip feet for secure contact on any training surface.
- Wide, supportive pad for consistent setup and powerful pressing mechanics.
- High-density padding designed for support without sink during high-volume training.
- Compact footprint ideal for racks, benches, dumbbell stations, and performance floors.
- Built for versatility: bench press, dumbbell work, rows, step-ups, and core training.
- Commercial-grade durability engineered for nonstop daily use.

### PRODUCT SPECS:

Length	47.50"/1207 CM
Width	30"/769 CM
Height	16.50"/421 CM
Weight	60 LB/27.2 KG



AMERICAN STRENGTH

# MULTI-ADJUSTABLE BENCH

## BNCH-MUTLI-AB

The American Strength Multi-Adjustable Bench is built for heavy training, fast transitions, and full-range versatility, from flat pressing to steep incline work. Designed with multiple back-pad positions for repeatable angles and consistent setup, it delivers a stable platform for dumbbell presses, shoulder work, rows, split stances, and accessory volume. The rigid steel frame stays planted under real loading, while the thick, supportive padding keeps athletes locked in rep after rep without shifting or sinking. One bench. Endless output.

### KEY FEATURES

- Multiple back-pad positions for flat-to-incline training and consistent mechanics.
- Stable, heavy-duty frame engineered for high loading and daily commercial abuse.
- Training-optimized pad geometry for clean setup and repeatable positioning.
- High-density padding for support without sink during heavy presses and volume work.
- Compact footprint perfect for racks, dumbbell zones, and performance floors.
- Built for versatility: presses, rows, seated work, step-ups, and core training.
- Commercial-grade durability designed to take constant use and keep performing.

### PRODUCT SPECS:

Length	51" / 1302 CM
Width	30" / 769 CM
Height	17" / 460 CM
Weight	120 LB / 54.4 KG
Positions	0-75 DEGREE



AMERICAN STRENGTH

# PLATE-LOADED DECLINE OLYMPIC BENCH

## BNCH-OLY-DEC-V2

The American Strength Decline Bench Press is built to hit pressing power from a stronger, more aggressive angle, driving serious lower-chest strength while keeping shoulders in a stable, locked-in position. Designed for confident setup and repeatable mechanics, it features secure leg rollers for firm bracing and consistent body positioning under load.

The heavy-duty steel frame stays planted for heavy attempts and high-volume sessions, while integrated plate storage keeps the station fast, organized, and always ready. This is decline pressing built for real output, clean reps, heavy weight, zero distractions.

### KEY FEATURES

- Fixed decline press angle to target the lower chest and drive pressing power.
- Secure leg roller system for bracing, stability, and consistent positioning.
- Multi-position bar catches for safe setup, liftoff control, and efficient re-racks.
- Heavy-duty steel construction engineered for high loading and commercial abuse.
- Integrated plate storage horns for fast changes and clean organization.
- Stable, wide base for confidence under heavy volume and heavy attempts.
- Built-in, non-slip spotter platform for secure footing and safer assistance on heavy lifts.
- Ideal for chest + triceps development in strength and hypertrophy programming.

### PRODUCT SPECS:

Length	83"/2115 CM
Width	70.50"/1790 CM
Height	55"/1400 CM
Weight	325 LB/147.4 KG



AMERICAN STRENGTH

# PLATE-LOADED INCLINE OLYMPIC BENCH

## BNCH-OLY-INC-V2

The American Strength Plate-Loaded Incline Olympic Bench is built to drive serious upper-body strength with rock-solid stability and efficient setup. Designed to lock athletes into a powerful pressing angle, it targets the upper chest, shoulders, and triceps with clean force output and consistent bar path control.

Integrated plate storage keeps loading fast and organized, while the heavy-duty frame and wide base stay planted under real weight and real training volume. Whether you're running strength blocks, hypertrophy work, or accessory progressions, this is the incline station built for relentless reps and long-term commercial abuse.

### KEY FEATURES

- Fixed incline press angle for consistent mechanics and upper-body power development.
- Stable, heavy-duty frame built to handle high loading and nonstop use.
- Multi-position bar catches for confident setup and safe re-racks.
- Integrated plate storage horns for fast loading and clean organization.
- Ergonomic bench + back pad support to keep athletes locked in and pressing hard.
- Built-in, non-slip spotter platform for secure footing and safer assistance on heavy lifts.
- Ideal for building upper chest, shoulders, and triceps with controlled output.
- Commercial-grade durability engineered for high-traffic training floors.



### PRODUCT SPECS:

Length	70"/1780 CM
Width	70.50"/1790 CM
Height	61"/1550 CM
Weight	280 LB/127 KG

AMERICAN STRENGTH

# PLATE-LOADED FLAT OLYMPIC BENCH

## BNCH-OLY-FLT-V2

The American Strength Plate-Loaded Flat Olympic Bench is built for pure pressing power, stable, efficient, and engineered for heavy loading. Designed to keep athletes locked into a strong, repeatable setup, it delivers a consistent bar path and confident re-racks rep after rep.

The heavy-duty frame stays planted under real weight, while integrated plate storage keeps loading fast and the training area clean. This is a no-nonsense bench station made for strength blocks, hypertrophy volume, and high-traffic commercial use, because serious pressing shouldn't come with excuses.

### KEY FEATURES

- Fixed flat press position for consistent mechanics and max strength output.
- Multi-position bar catches for safe setup, liftoff control, and efficient re-racks.
- Heavy-duty steel frame built to handle aggressive loading and daily abuse.
- Integrated plate storage horns for quick changes and clean organization.
- Stable, wide base for confidence under heavy attempts and high volume.
- Built for chest, triceps, and pressing power in strength and hypertrophy programs.
- Built-in, non-slip spotter platform for secure footing and safer assistance on heavy lifts.
- Commercial-grade durability engineered for nonstop gym traffic.

### PRODUCT SPECS:

Length	68.50"/1740 CM
Width	70.50"/1790 CM
Height	55"/1400 CM
Weight	215 LB/97.5 KG



AMERICAN STRENGTH

# PLATE TREE

## ST-WPT-V2

The American Strength Plate Tree is built to keep your training floor fast, clean, and battle-ready. Designed for efficient plate storage and rapid changeovers, it delivers a stable, compact footprint that keeps iron within arm's reach without cluttering the platform or slowing down the session.

Heavy-duty steel construction and multiple storage horns make it easy to organize bumpers and Olympic plates by weight, while the wide base keeps the unit planted under real gym traffic. Whether you're running strength circuits, coaching groups, or loading plate machines, this is the kind of storage that keeps momentum high and downtime low.

### KEY FEATURES

- Multiple storage horns for organized plate separation and quick access.
- Compact footprint to maximize floor space without sacrificing capacity.
- Heavy-duty steel frame built for commercial traffic and daily abuse.
- Wide, stable base for rock-solid storage, even when fully loaded.
- Fast changeover design to keep training moving and stations efficient.
- Ideal for bumpers + Olympic plates in strength zones, platforms, and plate-loaded areas.
- Durable powder-coated finish for long-term performance and clean aesthetics.

### PRODUCT SPECS:

Length	31"/792 CM
Width	34"/862 CM
Height	37"/940 CM
Weight	70 LB/31.50 KG



AMERICAN STRENGTH

# DUMBBELL RACK 2-10

## ST-DB-2T

The American Strength Dumbbell Rack 2-10 delivers unmatched strength, organization, and design. Built from heavy-gauge steel with precision-angled trays, it securely holds up to 10 pairs of dumbbells. Engineered for commercial performance and finished with a durable powder coat, this rack combines function and style to elevate any training environment, from professional facilities to elite home gyms.

### KEY FEATURES

- Holds up to 10 pairs of dumbbells.
- Heavy-duty steel frame ensures maximum durability and stability.
- Angled tiers for easy loading and unloading.
- Protective saddles prevent wear on equipment.
- Premium powder-coated finish resists scratches and corrosion.



### PRODUCT SPECS:

Length	98.2"/249.5 CM
Width	29.9"/75.8 CM
Height	22.8"/57.9 CM
Weight	178 LB/81 KG

AMERICAN STRENGTH

# DUMBBELL RACK W2-10

## ST-DB-2T-W

The American Strength Dumbbell Rack W2-10 is built to handle the heaviest and largest dumbbells with ease. Featuring a wider tray design and reinforced steel frame, this rack delivers superior stability and capacity for professional environments. Precision-engineered saddles keep dumbbells secure and organized, while the durable powder-coated finish withstands years of heavy use in commercial or elite training facilities.

### KEY FEATURES

- Holds up to 10 pairs of larger-diameter dumbbells.
- Extra-wide tray design for oversized dumbbells.
- Heavy-duty steel frame for maximum strength and stability.
- Angled tiers for easy access and loading.
- Protective saddles minimize dumbbell wear.
- Durable powder-coated finish resists corrosion and impact.
- Ideal for 105LB to 200LB dumbbells.



### PRODUCT SPECS:

Length	105.31"/267.5 CM
Width	26.89"/68.3 CM
Height	31.18"/79.2 CM
Weight	251 LB/114 KG

AMERICAN STRENGTH

# DUMBBELL RACK 3-15

## ST-DB-3T

The American Strength Dumbbell Rack 3-15 is built for serious storage and serious strength. Featuring three heavy-duty tiers, it holds up to 15 pairs of dumbbells while maintaining a compact footprint. Each precision-engineered tray provides secure placement and effortless access, and the robust steel frame delivers unmatched stability under heavy loads. With a durable powder-coated finish and premium design, this rack is built to perform in the toughest commercial training environments.

### KEY FEATURES

- Holds up to 15 pairs of dumbbells.
- Three-tier design maximizes storage capacity and floor efficiency.
- Heavy-gauge steel frame ensures long-term durability.
- Angled trays allow for easy loading and removal.
- Protective saddles minimize dumbbell wear.
- Durable powder-coat finish resists corrosion and impact.
- Perfect for 5LB - 75LB dumbbell sets.



### PRODUCT SPECS:

Length	98.2"/249.5 CM
Width	27.9"/70.9 CM
Height	40.8"/103.6 CM
Weight	254 LB/115 KG

AMERICAN STRENGTH

# ACCESSORY RACK

## ST-ACC-RCK-V2

The American Strength Accessory Rack delivers premium organization for small training essentials. Built from commercial-grade steel with a compact, space-saving footprint, this rack keeps your gear easily accessible and neatly displayed. Its tiered shelves and integrated hooks are ideal for storing a wide range of American Strength accessories, from kettlebells and medicine balls to collars, bands, cable attachments, and more. Designed for high-traffic environments, the Accessory Rack combines durability, versatility, and sleek professional style.

### KEY FEATURES

- Multi-tier design for compact, high-capacity storage.
- Ideal for kettlebells, slam balls, wall balls, cable attachments, resistance bands, collars, and other accessories.
- Heavy-duty steel frame for commercial use.
- Built-in hooks provide added organization for smaller items.
- Powder-coated finish resists impact and wear.



### PRODUCT SPECS:

Length	27.56"/70 CM
Width	37.01"/94 CM
Height	44.41"/112 CM
Weight	150 LB/68 KG

# RACKS & RIGS

**BUILT TO ANCHOR THE FLOOR AND POWER EVERY REP, THIS LINEUP COMBINES HEAVY-DUTY STEEL, MODULAR CONFIGURATIONS, AND PRECISION-GUIDED MOVEMENT TO SUPPORT EVERYTHING FROM HEAVY BARBELL WORK TO HIGH-VOLUME TRAINING, WITH UNCOMPROMISING STABILITY, SAFETY, AND PERFORMANCE.**



## PRODUCTS

• SMITH MACHINE



AMERICAN STRENGTH

# SMITH MACHINE

## PL-SMTH-RCK

The American Strength Smith Machine is built for controlled movement and high-volume training without wasted motion. Designed with a guided, counter-balanced bar system for consistent movement, this machine was designed for total body training and supports everything from heavy compound pressing to lower-body work, accessory training, and rehab-style control.

With integrated plate storage and a commercial-grade frame, this unit is engineered for real weight, real athletes, and nonstop facility traffic, giving lifters the confidence to train hard with precision and stability on every rep.

### KEY FEATURES

- Selectable bar-path functionality to support different training setups and athlete preferences.
- Multi-position racking points for efficient set-up, safe re-racks, and smooth training flow.
- Heavy-duty steel construction built for high loading and commercial abuse.
- Integrated plate storage horns for fast changeovers and clean organization.
- Versatile programming tool for presses, squats, lunges, rows, and accessory work.
- Ideal for strength, hypertrophy, and controlled movement where consistency matters.

### PRODUCT SPECS:

Length	56"/1412 CM
Width	29"/730 CM
Height	37"/931 CM
Weight	LB/ KG



**ENGINEERED FOR PERFORMANCE.**

**BUILT FOR STRENGTH.**



**SHOWROOM AND  
DISTRIBUTION**

701 W. SYCAMORE STREET, FRESNO, TX 77545

**TELEPHONE** (281) 972-9267

**EMAIL** [sales@americanstrength.com](mailto:sales@americanstrength.com)

**FOLLOW US**

